

Dimensions

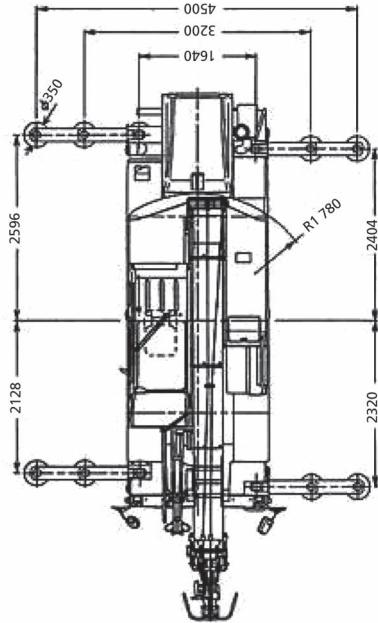

Right turn in two-wheel steering mode

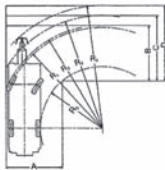

- R₁ = 6.50m (Minimum turning radius)
- R₂ = 6.60m (Turning radius of extremely outer tire)
- R₃ = 7.13m (Chassis turning radius)
- R₄ = 7.75m (Boom end turning radius)
- R₅ = 3.88m (Turning radius extremely chassis inner)
- A = 3.53m (Width of entrance)
- B = 3.53m (Width of wheel exit)
- C = 4.15m (Width of chassis exit)
- D = 4.79m (Width of exit at end of boom)

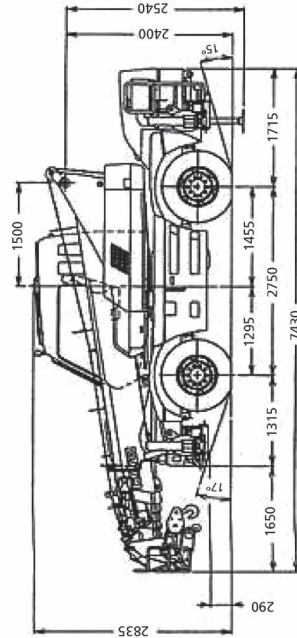

Right turn in four-wheel steering mode

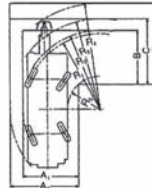

- R₁ = 3.92m (Minimum turning radius)
- R₂ = 4.02m (Turning radius of extremely outer tire)
- R₃ = 4.59m (Chassis turning radius)
- R₄ = 5.38m (Boom end turning radius)
- R₅ = 1.66m (Turning radius extremely chassis inner)
- A₀ = 3.45m (Width of entrance)
- A₁ = 2.80m (Width of wheel entrance)
- B = 2.75m (Width of wheel exit)
- C = 3.34m (Width of chassis exit)
- D = 4.01m (Width of exit at end of boom)

The charts that have been included have been reproduced from manufacturer specifications, and while every effort has been made to ensure their accuracy, we do not accept any responsibility for errors or omissions. We also need to draw your attention to the guidance notes on page 47 to assist you with your crane selection.



Main Boom Duties

Radius (m)	Outriggers fully extended (4.5m) 360° full range						Outriggers intermediately extended (3.2m) 360° full range						Outriggers completely retracted (Blocked on vertical cylinders) - 360° full range					
	5.5	9.1	12.7	16.3	19.9	23.5	5.5	9.1	12.7	16.3	19.9	23.5	5.5	9.1	12.7	16.3	19.9	23.5
1.5	10	5	5				10	5	5				8	5	4.9			
2	10	5	5	4			10	5	5	4			5.5	4	3.5	3.25		
2.5	10	5	5	4			10	5	5	4			3.7	3.15	2.6	2.5		
3	8	5	5	4	4		8	5	5	4	4		2.7	2.35	1.95	1.95	1.9	
3.5	6.1	5	5	4	4		6.1	5	5	4	4		2.1	1.85	1.5	1.55	1.55	1.5
4	5.2	5	5	4	4	2.3	5.2	4.45	4.3	4	4	2.3	1.6	1.45	1.15	1.25	1.2	1.2
4.5		5	4.55	4	3.7	2.3		3.9	3.55	3.5	3.4	2.3		1.1	0.85	1	1	1
5		4.4	4.1	3.7	3.4	2.3		3.35	3	2.95	2.3		0.85	0.65	0.8	0.85	0.85	
5.5		3.95	3.7	3.4	3.1	2.3		2.8	2.55	2.6	2.55	2.3		0.65	0.45	0.6	0.65	0.7
6		3.55	3.35	3.15	2.85	2.3		2.35	2.2	2.25	2.25	2.1		0.5	0.3	0.45	0.55	0.55
6.5		3.15	3.05	2.9	2.6	2.15		1.75	1.9	2	2	1.95		0.35	0.2	0.35	0.4	0.45
7		2.8	2.8	2.65	2.4	2		1.5	1.65	1.75	1.75	1.75		0.25				
8		2.5	2.3	2.25	2.05	1.75		(7.5m)	1.2	1.35	1.4	1.4						
9		(7.5m)	1.9	1.95	1.8	1.55		0.9	1.05	1.1	1.15							
10		1.5	1.7	1.6	1.40			0.65	0.8	0.9	0.9							
11		1.2	1.4	1.4	1.25			0.45	0.6	0.7	0.75							
12			1.15	1.25	1.15				0.45	0.55	0.6							
13			0.95	1.05	1.05				0.3	0.45	0.5							
14			0.78	0.90	0.95				0.2	0.35	0.35							
15			0.7	0.75	0.84					0.25	0.3							
16			(14.5m)	0.63	0.7						0.2							
17				0.53	0.6													
18				0.44	0.5													
19					0.42													
20					0.35													
21					0.28													
22					0.24													
standard hook	for 10 ton						for 10 ton						for 10 ton					
Hook Mass	80kg						80kg						80kg					
Parts of Line	8			4			8			4			8			4		
Critical Boom Angle	--	--	--	--	--	--	--	--	--	25°	35°	--	--	52°	59°	64°	68°	

(Unit: Metric ton)

The charts that have been included have been reproduced from manufacturer specifications, and while every effort has been made to ensure their accuracy, we do not accept any responsibility for errors or omissions. We also need to draw your attention to the guidance notes on page 47 to assist you with your crane selection.

Fly Jib Duties

City & Low
Headroom Cranes

23.5m Boom + 2.5m Jib						
Outriggers fully extended (4.5m) - 360° full range						
Boom Angle (°)	Offset 15°		Offset 30°		Offset 45°	
	Working Radius (m)	Load (t)	Working Radius (m)	Load (t)	Working Radius (m)	Load (t)
81	4	1.2	4.5	1	5	0.8
77.5	5.7	1.2	6.2	1	6.5	0.8
73	7.7	1.2	8.2	1	8.4	0.76
70	8.9	1.08	9.4	0.92	7.6	0.74
65	11	0.9	11.4	0.81	11.6	0.7
60	12.9	0.8	13.3	0.73	13.5	0.68
55	14.8	0.7	12.1	0.66	15.2	0.63
50	16.5	0.64	16.7	0.61	16.8	0.59
46.5	17.6	0.58	17.9	0.57	18	0.56
40	19.4	0.42	19.7	0.41		
32	21.4	0.28	21.5	0.28		
25	22.7	0.2				
Standard hook	for 1.4 ton					
Hook mass	25kg					
Parts of line	1					
Critical Boom Angle	15°		30°		45°	

23.5m Boom + 2.5m Jib						
Outriggers intermediately extended (3.2m) - 360° full range						
Boom Angle (°)	Offset 15°		Offset 30°		Offset 45°	
	Working Radius (m)	Load (t)	Working Radius (m)	Load (t)	Working Radius (m)	Load (t)
81	4	1.2	4.5	1	5	0.8
77.5	5.7	1.2	6.2	1	6.5	0.8
73	7.7	1.2	8.2	1	8.4	0.76
70	8.9	1.08	9.4	0.92	9.6	0.74
67.5	10	0.98	10.4	0.86	10.7	0.72
65	11	0.81	11.4	0.74	11.6	0.7
60	12.9	0.54	13.3	0.52	13.4	0.5
55	14.7	0.35	15.1	0.33	15.2	0.33
50	16.5	0.2	16.7	0.2	16.8	0.2
Standard hook	for 1.4 ton					
Hook mass	25kg					
Parts of line	1					
Critical Boom Angle	49°		49°		49°	

The charts that have been included have been reproduced from manufacturer specifications, and while every effort has been made to ensure their accuracy, we do not accept any responsibility for errors or omissions. We also need to draw your attention to the guidance notes on page 47 to assist you with your crane selection.

